

2. Make a marble run

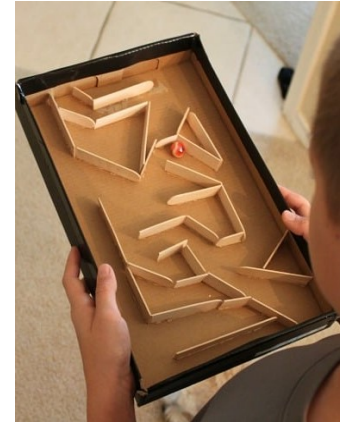
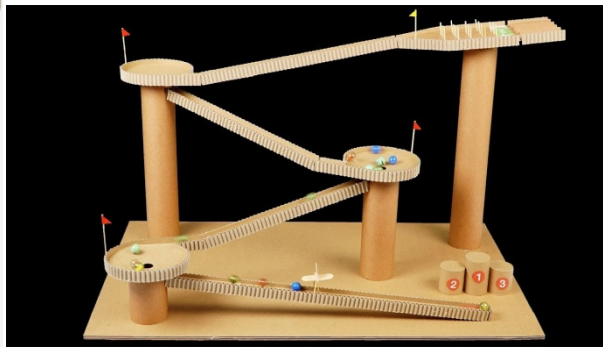

- Can you make a design that **works and looks good**?
- Can you choose and use **materials** and use **tools**?
- Can you build **structures**, exploring how they can be made **stronger and more stable**?
- Can you **evaluate** your work?

WHAT MATERIALS TO USE

You can use cardboard, plastic, wood, or anything else that works well and you can get at home.

Try looking in your recycling box.

HERE'S WHAT WE USED:

1. CARDBOARD
2. SELLOTAPE
3. SCISSORS
4. EGG CARTON
5. PAPER
6. MARBLE (or make your own)
7. CARDBOARD TUBES
8. FELT TIPS - to decorate



INSTRUCTIONS



1.

Find something to act as a backboard for your marble run – this can be as big or small as you would like.

Some good ideas are a cereal box or a shoe box lid, but any piece of cardboard will do.

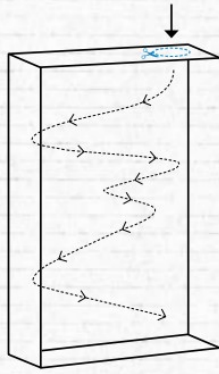

2.

If needed, cut an entrance for your marble to enter at the top.

Now design the route your marble will take.

You could trace out where you want your marble to go or freehand it.

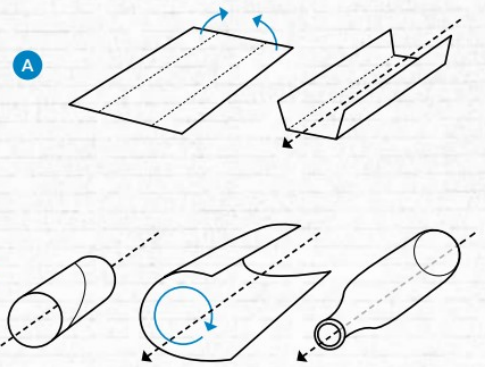

3.

There are many ways for your marble to make it to the bottom:

- A To make “steps”, cut out a strip of cardboard, make sure it is wide enough to fold two tabs and for the marble to fit on. Fold the strip on both edges – one to stick to your backboard and use the other to keep the marble on course.
- B You could also use toilet roll tubes or roll paper tubes to make tunnels, or plastic bottles to act as a funnel. Just make sure your marble fits through these.

INSTRUCTIONS

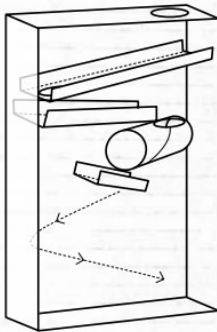

4.

Stick your steps to your backboard. The most important thing to remember is that they must be on an angle so that gravity can work on your marble.

Make sure to test that your marble follows the path as you are building.

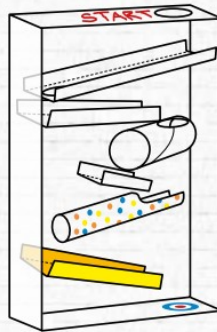

5.

Decorate your design with felt tips or coloured card to make it stand out.



6.

Time to test your completed marble run!